

OPTOD NUMERICAL SENSOR (Plastic version) User manual



For Sales & Service Contact

geotech

2650 E. 40th Ave. • Denver, CO 80205
Phone 303-320-4764 • Fax 303-322-7242

1-800-833-7958

www.geotechenv.com

CONTENTS

1. GENERAL	3
2. CHARACTERISTICS	4
2.1 Technical characteristics.	4
2.2 CE compliance.....	5
3. DESCRIPTION.	6
3.1 Product overview	6
3.2 Applications	6
3.3 Construction and dimensions.	7
3.4 Communication.	8
3.4.1 Modbus RTU registers.	8
3.4.2 SDI12 frame.....	8
3.5 Compensation.....	8
3.5.1 Influences on the measurement.	8
3.5.2 Temperature compensation.	8
3.5.3 Atmospheric pressure.	8
3.5.4 Salinity.....	9
3.6 Sampling rate.....	9
4. INSTALLATION.	9
4.1 Sensor installation option	9
4.1.1 Accessories for immersion installation.	9
4.2 Installation of the sensor in the accessories of assembly	11
4.2.1 Insertion in a pole.	12
4.3 Electrical connections.....	13
5. START-UP AND MAINTENANCE.	14
5.1 Initial startup	14
5.2 Calibration	15
5.2.1. Calibration in 2 points.	15
5.2.2. Calibration in 1 point.....	16
5.3 Maintenance.....	16
5.3.1. Cleaning.....	16
5.3.2. Change of the DODISK.....	17
5.3.3. Storage.	17

1. General

In order to maintain and ensure the good working order of the OPTOD Plastic sensor, users must comply with the safety precautions and warnings featured in this manual.

Assembly and activation:

- Assembly, electrical connection, activation, operation and maintenance of the measuring system must only be carried out by specialist personnel authorized by the user of the facilities.
- Trained personnel must be familiar with and comply with the instructions in this manual.
- Make sure the power supply complies with the specifications before connecting the device.
- A clearly-labeled power switch must be installed near the device.
- Check all connections before turning the power on.
- Do not attempt to use damaged equipment: it may represent a hazard and should be labeled as faulty.
- Repairs must only be carried out by the manufacturer or by AQUALABO's after-sales service department.

➤ Marking on the body of the sensor:

The marking on the body of the sensor indicates the serial number of the sensor (for the traceability) and the LOGO CE.



1	Datamatrix (contains the serial number)
2	Serial number OPTOD sensor: SN-PODOJ-YYYY X : version YYYYY : number
3	CE mark

2. Characteristics

2.1 Technical characteristics.

The technical characteristics can be modified without advance notice.

Measures	
Measure principle	Optical measure by luminescence
Measure ranges	0,00 to 20,00 mg/L 0,00 to 20,00 ppm 0-200%
Resolution	0,01
Accuracy	+/- 0,1mg/L +/- 0,1 ppm +/- 1 % (+/-5% if EMI Perturbations are more than 10V/m) The sensor must be fully immersed to ensure maximum precision
Limit of detection	0.7 %
Limit of quantification	2.2 %
Repeatability (100% Sat)	0.2 %
Linearity	>0.99
Response time	0-> 100 %; T90< 40s 100 -> 0%; T90< 65 s
Frequency of recommended measure	>5 s
Water Flow	no movement required for measurement
Temperature compensation	Via NTC
Temperature	0.00-50.00 °C Accuracy: +/- 0.5 °C
Stocking temperature	- 10°C to + 60°C

Sensor	
Dimensions	Standard version: Diameter: 27 mm ; length : 143 mm Longer version: Diameter: 27 mm ; length : 166 mm
Weight	300 g (sensor + cable 3 m)
Wetted material	Black POMC, PVC Cable: polyurethane jacket Steam gland: Polyamide Patch with active material (black) – DO DISK : Optical isolation silicon
DO disk	No cross-sensitivity with: pH 1 – 14; CO ₂ , H ₂ S, SO ₂ Cross-sensitivity to Organic solvents, such as acetone, toluene, chloroform or methylene chloride Chlorine gas
Maximum pressure	5 bars
IP classification	IP68
Connection	9 armoured connectors, polyurethane jacket, bare-wire
Sensor cable	Standard: 3, 7 and 15 m (other length on request). 100 m Max.

2.2 CE compliance.

Pursuant to the article 11 of the directive 89 / 336 / EEC relative to the electromagnetic compatibility.

We declare that the digital sensor of the range DIGISENS sensor OPTOD was tested and declared in compliance with the European standards:

Standard tests: NF EN IEC 61326-1: 2021-06

NF EN IEC 61326-1 (2021-06)

Electrical equipment for measurement, control and laboratory use – EMC requirements –
Part 1: General requirements.

2.2. NORMATIVE REFERENCES [1]

NF EN 55011: 2016-06 +/A1 : 2017-06 +/A2 : 2021-04

Industrial, scientific and medical equipment – Radio-frequency disturbance characteristics – Limits and methods of measurement.

Immunity: Radiated immunity EN 61000-4-3 Industrial environment – Criteria A

ESD (Electrostatic discharge) EN 61000-4-2 Industrial environment - Criteria B

RF Common mode EN 61000-4-6 Industrial environment - Criteria A

Surge EN 61000-4-5 Industrial environment - Criteria B

Fast Transients EN 61000-4-4 Industrial environment – Criteria B

Disturbance: EN 55011B

Radiated emissions - EN 55011 Group 1 - Class A

Conducted emissions - EN 55011 Group 1 - Class A

Identification of the measurement process composed of:

- 1- one probe
- 2- Ponsel's cable. EN 61000-4-5

Commercial Name: DIGISENS range

Manufacturer AQUALABO
90, Rue du Professeur P. Milliez
94506 Champigny sur Marne

Responsible UE: AQUALABO
90, Rue du Professeur P. Milliez
94506 Champigny sur Marne

3. Description.

3.1 Product overview

The OPTOD dissolved oxygen sensor applies the luminescence-based optical measurement technology and measures reliably and accurately without requiring calibration.

With no consumables or maintenance required, the OPTOD sensor gives an immediate return on the investment. The only intervention required is to replace the DO disk every two years.

Since it does not consume oxygen, the OPTOD sensor can be used in all media; even when there is a very weak flow of water.

The OPTOD sensor offers the following advantages:

- Low operating costs due to reduced maintenance work (no electrolyte changes)
- Greater calibration intervals due to low drift behaviour
- No polarization voltage required
- High measuring accuracy, even for low concentrations
- Rapid response times
- No minimum inflow (no oxygen consumption);

The sensor features excellent interference immunity thanks to the integrated preamplifier and digital signal processing. The measured value for dissolved oxygen is automatically compensated with the temperature, air pressure, and salinity (salt content), and transferred without interference to the connected display unit and controller via a digital interface. The membrane cap is easy to replace, meaning the sensor is very easy to maintain. The current calibration data is saved directly in the sensor electronics. As a result, the Plug and Play function of the system is enabled without the need for recalibration. The sensor also includes a log book containing the last ten successful calibrations in the form of a ring buffer.

3.2 Applications

The compact and robust plastic sensor is particularly well suited to the following typical areas of application:

- Monitoring of surface waters, coastal waters, aquariums,
- Fish farming: closed containment, offshore,
- Fish farming, aquaculture,

3.3 Construction and dimensions.

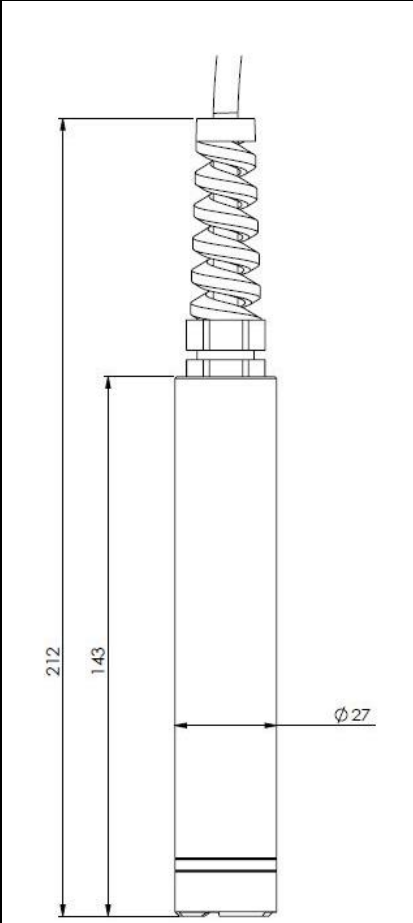
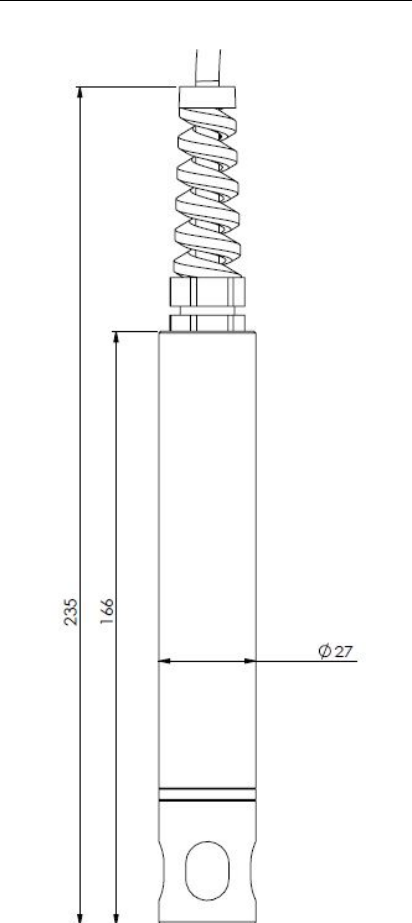

- (1) Protective strainer (2 versions: standard and longer)
- (2) DODISK on plastic support
- (3) DODISK Gasket
- (4) Gasket
- (5) Sensor's body with electronic part
- (6) Cable gland
- (7) Securely connected connection cable

Dimensions	
Standard strainer	Longer strainer
	

3.4 Communication.

3.4.1 Modbus RTU registers.

The link protocol must correspond to MODBUS RTU.

See document:

- Modbus_over_serial_line_V1_02.pdf
- Modbus_Application_Protocol_V1_1a.pdf
- Modbus memory for PONSEL digital Sensors:
SENSOR_TramesCom_xxx_UK.xls (refer to www.aqualabo.fr)

The Modbus memory plane is identical for each parameter of the Sensors.

The Modbus protocol for the Sensors allows you to measure the parameter (+ temperature) of the Sensor and to calibrate the parameter (+ temperature). Furthermore, there are certain numbers of functions such as:

- Select the averaging value
- Read the Sensor description
- Return to default coefficients
- Modify the Sensor address
- Information on measures conducted (Out Of Specification measures, measures in progress, etc.).
- Date and name of the operator who performed the calibration
- etc.

To have more information on the open PONSEL's Modbus protocol please consult the last version of the following documents:

- the pdf file: Modbus_SpecificationsVxxx-EN
- the excel file: Digital sensor Frame_XXX_UK

3.4.2 SDI12 frame.

A list of SDI12 registers is available for network communication. Refer to www.aqualabo.fr for more information.

3.5 Compensation

3.5.1 Influences on the measurement.

The oxygen measurement is dependent on parameters:

- The temperature of the measurement medium
- The air pressure (atmospheric pressure)
- The salinity of the measurement medium

The degree of solubility of oxygen in water is dependent on the temperature, the salinity, and the air pressure. This dependency is stored in the sensor's measurement electronics in the form of functions. The sensor can therefore determine the oxygen concentration of the measurement medium, in order to digitally transmit the influencing factors above, in compensated form, to the transmitter/controller.

3.5.2 Temperature compensation.

The temperature compensation is automatic and managed directly by the sensor via the integrated sensor of temperature (NTC).

3.5.3 Atmospheric pressure.

With the most frequently used calibration method – end value calibration of the sensor in water vapor-saturated air – the air pressure must be taken into account.

For this purpose, the air pressure can, for example, be transmitted to the sensor by the way of your terminal, where it is saved.

By default, the value of the atmospheric used for the compensation is 1013 hPa.

3.5.4 Salinity.

The value for the salinity of the measurement medium could be transmitted to the sensor by the way of your terminal.

By default, the value of the salinity used for the compensation is 0 g/Kg.

3.6 Sampling rate

Optical oxygen sensors do not carry out any continuous measurements. To extend the operating life of the optical membrane, the measurement interval can be set to a value superior to 10 seconds.

4. Installation.

4.1 Sensor installation option

For the installation of the sensors in condition of immersion or in-pipe insertion, we advise to use accessories adapted and proposed by AQUALABO.

4.1.1 Accessories for immersion installation.

In immersion condition, it is necessary to maintain the sensor by the body and not to leave the sensor suspended by the cable at the risk of damaging the sensor
 AQUALABO proposes a range or pole (short and long version) in order to install the sensor in open basins. It can be positioned a considerable distance from the basin edge with the bracket suspended on a chain, for example. Please note the following when planning your set-up:

- The fitting must be easily accessible to allow the sensor or the fitting itself to be maintained and cleaned regularly
- Do not allow the fitting (and thus also the sensor) to swing against and hit the basin edge
- When working with systems involving pressure and/or temperature, ensure that the fitting and sensor meet all relevant requirements
- The system designer must check that the materials in the fitting and sensor are suitable for the measurement (chemical compatibility, for instance)

Material	PVC
Admissible temperature	0 to 60 °C
Pressure max.	5 bars

➤ Short pole

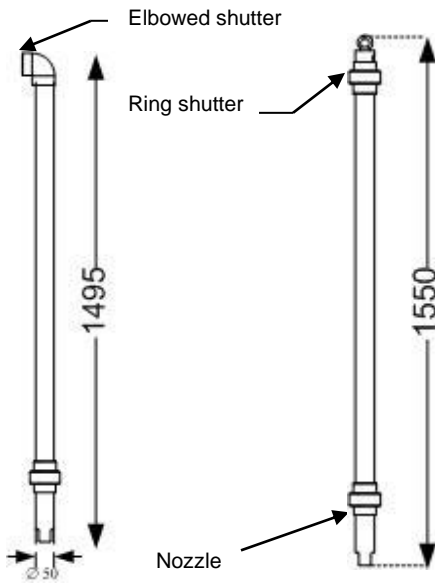

The short pole is available in 2 versions:

- **version with elbowed shutter**. The nozzle of support is included in the offer.

PF-ACC-C-00486	90° ELBOW SHORT PERCH FOR PLASTIC OPTOD SENSOR (1495 mm, ELBOWED SHUTTER)
----------------	---

- **version with shutter for mounting with chain**, nozzle of support is included in the offer.

PF-ACC-C-00487	90° ELBOW SHORT PERCH FOR PLASTIC OPTOD SENSOR (1550 mm, RING SHUTTER)
----------------	--

➤ Long pole

The long poles are available in elbow version, for installations in aeration basin, and straight, for applications in open channel. Every pole is equipped with an elbowed shutter and with waterproofness joints. The lower part includes a nozzle which is adapted to the sensor what assures its mechanical support.

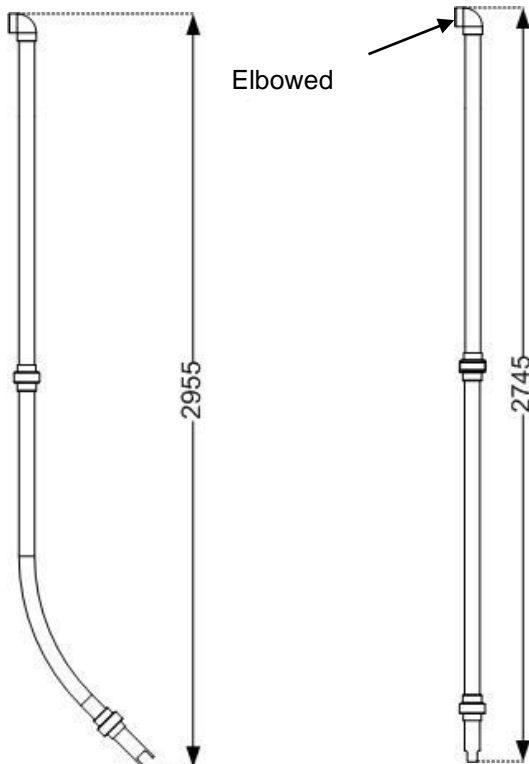

- **Elbowed pole with elbowed shutter**

PF-ACC-C-00484	90° ELBOW LONG PERCH FOR PLASTIC OPTOD SENSOR (2955 mm, ELBOWED SHUTTER)
----------------	--

- **Straight long pole with elbowed shutter**

PF-ACC-C-00485	STRAIGHT LONG PERCH FOR PLASTIC OPTOD SENSOR (2745 mm, ELBOWED SHUTTER)
----------------	---

➤ **Mounting accessories for pole.**

The elements of fixation for the poles are flexible and specially studied to adapt themselves to the different configurations of assembly.

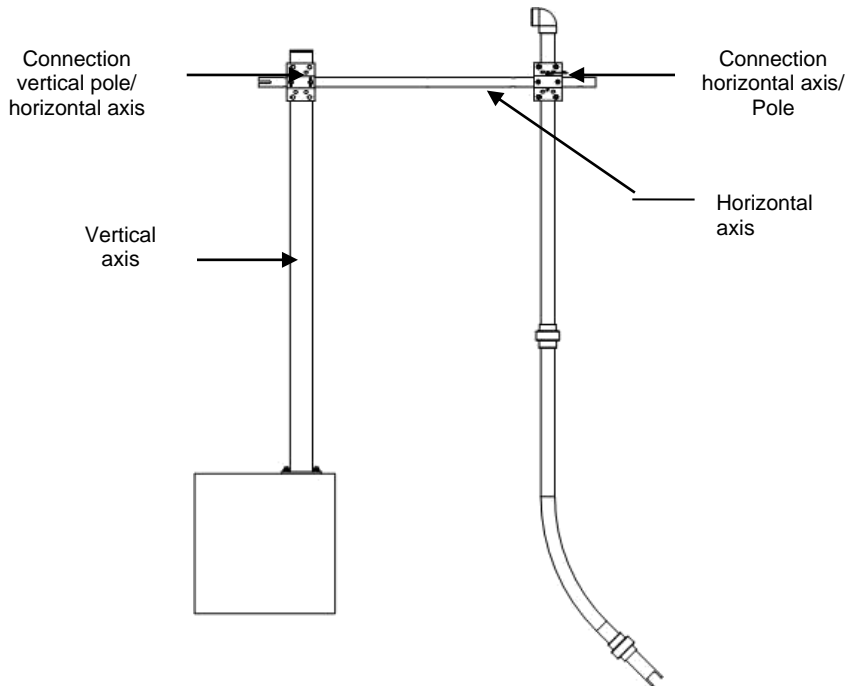

- Pole kit fixation

NC-ACC-C-00009	POLE FIXATION KIT FOR NUMERICAL SENSOR (ON LOW WALL)
NC-ACC-C-00010	POLE FIXATION KIT FOR NUMERICAL SENSOR (ON LIFE LINE)
NC-ACC-C-00011	POLE FIXATION KIT FOR NUMERICAL SENSOR (ON VERTICAL AXIS)
PF-ACC-C-00272	VERTICAL AXIS FOR NUMERICAL SENSOR POLE (TO BE FIXED ON SOIL)

Example of mounting on vertical axis

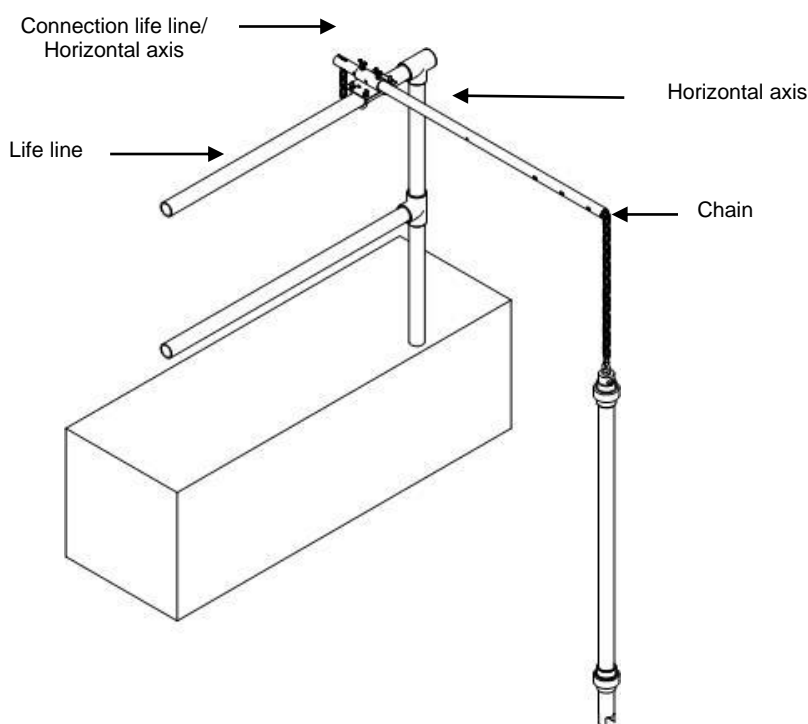

Example of mounting on life line

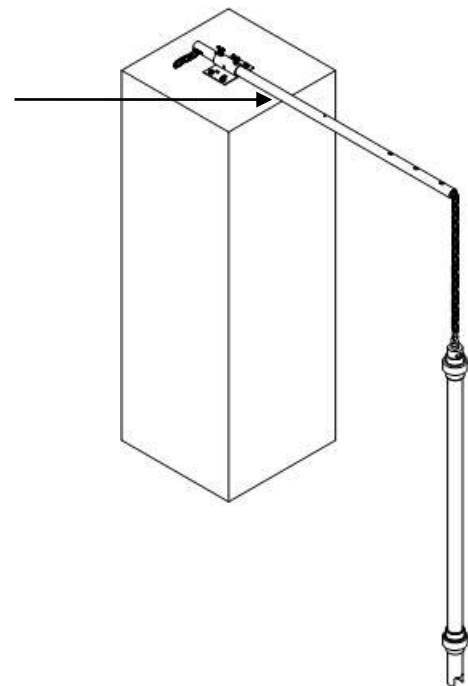

Example of mounting on low wall

- Accessories kit for assembly of poles with chain.

NC-ACC-C-00012	SHORT POLE FIXATION KIT FOR NUMERICAL SENSOR (ON LOW WALL)
	SHORT POLE FIXATION KIT FOR NUMERICAL SENSOR (ON LIFE LINE)
NC-ACC-C-00014	SHORT POLE FIXATION KIT FOR NUMERICAL SENSOR (ON VERTICAL AXIS)

4.2.1 Insertion in a pole.

The sensor is mounted on the relevant fitting as described below, using a sensor holder, which can be used both for the short and long pole:

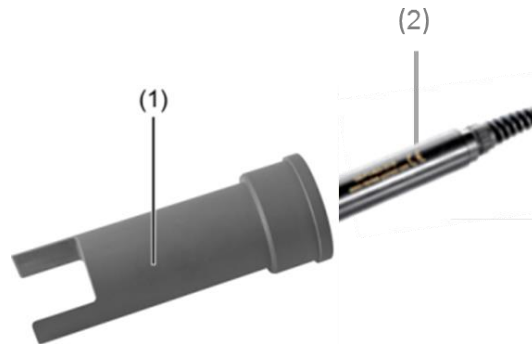

- 1 Remove the protective cap on the sensor and insert the sensor (2) into the nozzle (1) as far as the stop..
- 2 Insert the sensor cable into the fitting pipe (6) and completely feed through.

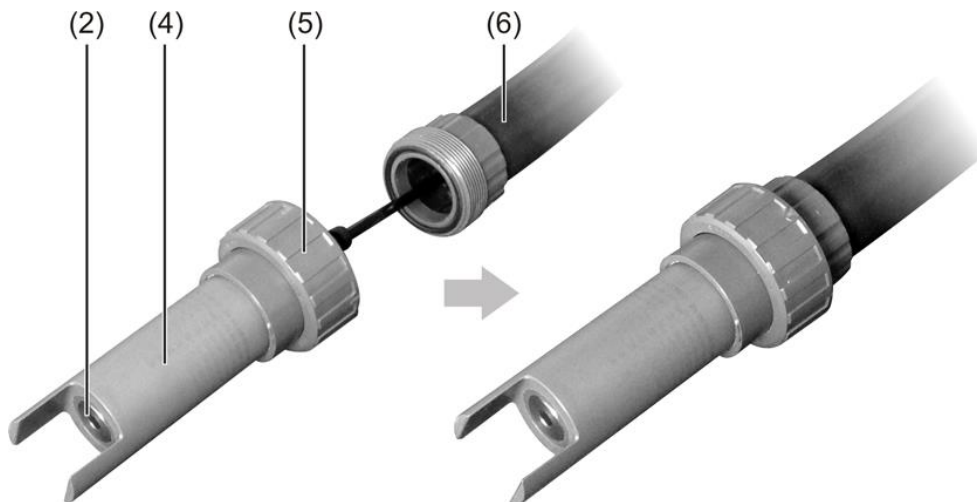

- 3 Screw the sensor holder with the union nut (5) onto the fitting pipe (6) and tighten until handtight.

4.3 Electrical connections.

The sensor could deliver within version bare wire on 3, 7, 15 m or on other length (up to 100 m).

Communication - Power supply	
Signal interface	Modbus ¹ RS-485 or SDI-12 ^{2,3} ^{1,2} The sensor responds in Modbus / SDI12 including during Standby ³ The use and connexion of SDI12 bus may increase the standby power consumption* up to 100uA depending the level of the line (high or low). The consumption is not increased if the SDI12 line is disconnected or released to 0V (Modbus RTU only)
Sensor power-supply (RS485 and SDI12)	5 V ^{1,2} to 12 ^{3,4} V DC (warm-up time 100 ms) ¹ Absolute minimum 4.5V with 1m of cable, boot and precision not guaranteed under 5V ² Minimum voltage subjected to cable length-related losses ³ 13V Absolute maximum with a more than 2 mA continuous over consumption ⁴ Small over consumption between 12V and 12.5V
Typical Consumption at 5V (RS485) <i>Recommended for ultra- low power (1 measure uses less than 18 uWh) Subject to modifications in case of internal parts evolution</i>	Automatic standby less than 22 µA* (110 µW) Maximum peak current: RS485 55 mA (2 ms) Maximum current during the measurement: 19.5 mA (97.5 mW) Average current during the measurement: 13 mA (65 mW) Average current RS485 (1 meas. / seconde): 3 mA (15 mW)
Typical Consumption at 12V (RS485) <i>Never exceed 12.0V for low power (1 measure uses less than 43 uWh) Subject to modifications in case of internal parts evolution</i>	Automatic standby less than 25 µA* (300 µW) Maximum peak current: 80 mA (2.5 ms) Maximum current during the measurement: 20.5 mA (246 mW) Average current during the measurement: 14 mA (168 mW) Average current RS485 (1 meas. / seconde): 3.2 mA (38.4 mW)
Typical Consumption at 12.5V (RS485) <i>Not recommended for low power Subject to modifications in case of internal parts evolution</i>	Automatic standby less than typical 35 µA* (438 µW) max 1 mA Maximum peak current: 85 mA (3 ms) Maximum current during the measurement: 21 mA (262.5 mW) Average current during the measurement: 18 mA (225 mW) Average current RS485 (1 meas. / seconde): 3.2 mA (40 mW)
Typical Consumption at 12V (SDI12) <i>Never exceed 12.0V for low power Subject to modifications in case of internal parts evolution</i>	Automatic standby less than 25 µA* (300 µW) Maximum peak current: 85 mA (3 ms) Maximum current during the measurement: 27 mA (324 mW) Average current during the measurement: 18 mA (216 mW) Average current (1 meas. / seconde): 6 mA (72 mW)

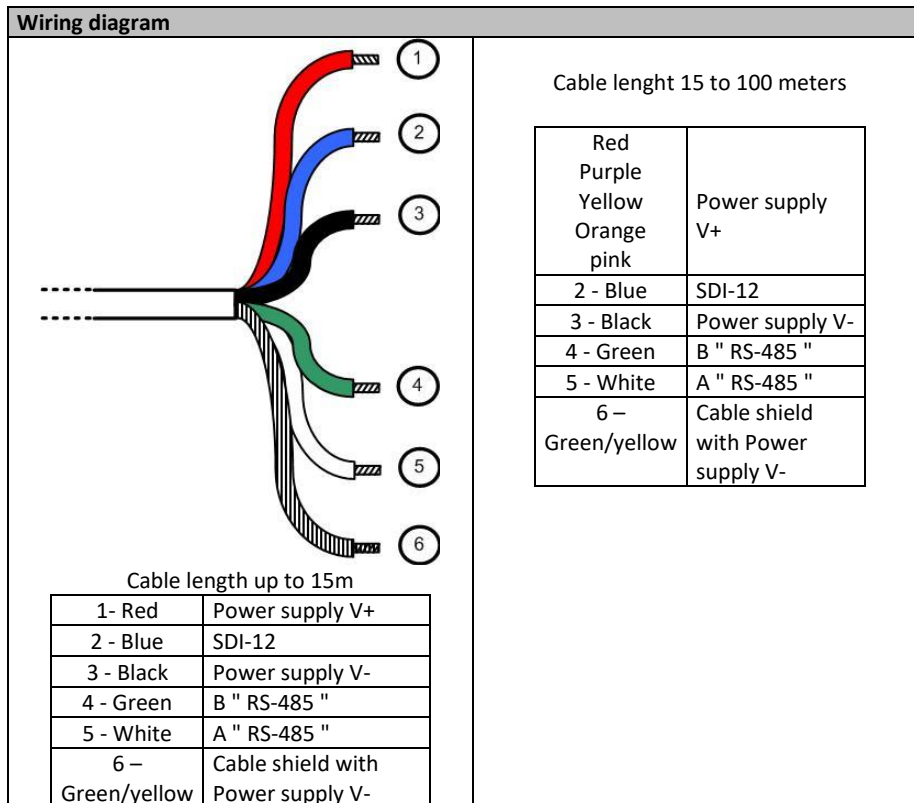

Note:

Never exceed a voltage of 10VDC (absolute maximum rating) on communication lines RS485, A or B, under penalty of irreversible destruction of the transceiver component RS 485.

SDI-12: respect the voltage value described in the associated standard (nominal: 5 VDC)

Always connect ground + shield first.

5. Start-up and maintenance.

5.1 Initial startup

Once the sensor is connected to your terminal, the sensor is settled in its accessory of assembly and the parameterization has been carried out on the display unit, the sensor is ready for initial start-up.

➤ **Note:**

For measurement, you must eliminate bubbles trapped under the membrane.

Presence of chlorine will distort the measure (overestimation of dissolved oxygen level).

During the introduction of the sensor in measurement environment, wait for sensor's temperature stabilization before measure processing.

To optimize a sustainable functioning of your probe, we recommend you to respect a frequency of measure superior to 10 seconds.



The membrane is vulnerable to: chemicals (organic solvents, acids, peroxide), mechanical treatments (impact, abrasion, tearing).

➤ **Started:**

Remove the black cap of protection (by holding the sensor head downward and by unscrewing the hood towards the right).

The sensor is delivered dry and the DODISK must be rehydrated so that the measures are optimized.

After dry storage, rehydrate the membrane for a 12 hours period (one night) in clear water.

5.2 Calibration

The sensor is calibrated to specification at the factory. The manufacturer does not recommend calibration unless periodically required by regulatory agencies. If calibration is required, let the sensor come to equilibrium with the process before calibration. Do not calibrate the sensor at setup.

After the membrane cap is replaced, calibration should be carried out.

It is also advisable to regularly clean the sensor (see the chapter maintenance: 5.3);

5.2.1. Calibration in 2 points.

With two-point calibration, the zero point (0% - offset) and slope (100 %) of the sensor are calibrated. This calibration method offers the greatest possible level of accuracy and is particularly recommended for measurements of small oxygen concentrations.

It is carried out as follows:

➤ **Offset calibration:**

- The sensor beforehand cleaned (to see chapter maintenance 5.3) is immersed in a water-sulphite solution (sulphite concentration < 2 %) in order to determine the zero point (0 % saturation). Mix the solution with the sensor so that the saturation in oxygen decreases more quickly (The oxygen fixed to the DODISK) must be consumed),



CAUTION!

Damage to the sensor membrane due to chemicals.

A damaged membrane can lead to incorrect measurement results.

The sensor membrane must not be in contact with the sulphite solution for longer than one hour.

- Washing (with clear water) and drying the sensor,

➤ **Slope calibration:**

- Sensor slope is determined by positioning in oxygen-saturated environment (100 % saturation.

The slope of the sensor is calibrated beyond the defined state of 100 % oxygen saturation. This state can in principle be achieved in two ways:

- By positioning the sensor in water vapor-saturated air (for example, directly over a water surface).
- By positioning the sensor in air-saturated water (air is directed through water until the water is saturated with it). The illustration below is a representation of the conditions in air- saturated water.

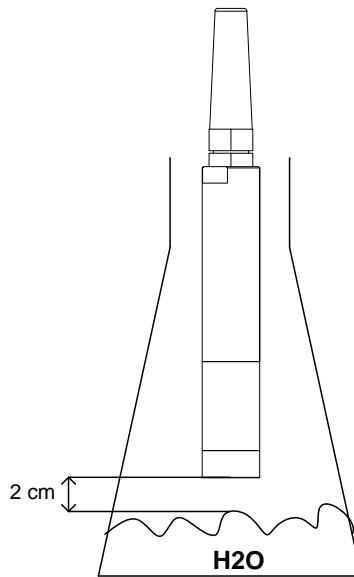

- The sensor must be kept dry during the calibration process. Drops of water adhering to the sensor membrane could distort the measurement result.
- The air pressure and temperature must remain constant during the calibration.

5.2.2. Calibration in 1 point.

The calibration in 1 point consists in propping up a 100% point: please consult the above chapter (slope calibration).

5.3 Maintenance

The maintenance schedule shows minimum intervals for regular maintenance tasks. Perform maintenance tasks more frequently for applications that cause electrode fouling.

Note: Do not disassemble the probe for maintenance or cleaning.

- The sensor must always be kept clean, particularly in the area around the optical membrane. The presence of a biofilm on the membrane cap can lead to measuring errors.
- A dirty membrane should be cleaned with warm, soapy water. A soft sponge should be used for cleaning (not an abrasive scouring sponge).
- If the sensor is put out of operation, it should be rinsed prior to being stored, and the protective cap should be fitted with the protective case and a moist absorbent surface (like cotton).

5.3.1. Cleaning.

Rinse meticulously the sensor and the membrane with clear water.

If deposits like biofilm or mud persist, wipe the membrane gently with a sweet cloth or an absorbent paper.



Attention: For the Titanium version clean the body of the sensor by means of acetone (do not use methylated spirit, ethanol or methanol).

5.3.2. Change of the DODISK.

The average life time of the DODISK is of 2 years.

In case of deterioration of the DODISK or of difficulty on the processes of calibration, the DODISK will be to change.



Open the black pouch and take out the active tablet (DODISK on white plastic holder) and the seal.



Hold the sensor vertically in the air.
Unscrew the strainer to access the used DODISK. Remove the gasket and the used DODISK.



Hold the sensor vertically.
Check the groove for foreign matter.
Position the 16 x 1 O-ring in the groove.



Hold the sensor vertically.
Position the DO-Disk and its holder, head-centered, with the black surface of the DO-Disk visible.



Hold the sensor vertically.
Screw the strainer to the stop, the DO-Disk holder will center with the tapping.

Rehydrate the membrane for a 12 hours period and recalibrate the sensor in 2 points (chapter 5.2.1)



Attention: do not unscrew the strainer containing the DODISK only in case of change.

5.3.3. Storage.

With the aim of keeping the active pastille operational quickly, keep the membrane hydrated with the protective case and a moist absorbent surface (like cotton wool).

After dry storage, rehydrate the membrane for a 12 hours period.